

## How to Make a Pieced Tunic (Nockert Type 1 Tunic)

### Materials Needed

2-3.5 m of prewashed woven fabric, 115 cm wide or wider  
 Sewing machine with a straight and a zigzag stitch  
 200 m of thread to match your fabric  
 Fabric scissors (the ones with the bent handles)  
 Dressmakers pins  
 Measuring tape  
 Tailors chalk or pencil (or a sliver of soap)  
 Needle for handsewing  
 Iron, and ironing board or towel

### Required Measurements

Chest measurement: \_\_\_\_\_ /2+2= A: \_\_\_\_\_

Shoulder to Hem: \_\_\_\_\_ x2+6= B: \_\_\_\_\_

Natural Waist to Hem: \_\_\_\_\_ = C: \_\_\_\_\_

Sleeve Measurement: \_\_\_\_\_ +2= D: \_\_\_\_\_

Biceps Measurement: \_\_\_\_\_ +3= E: \_\_\_\_\_

Hand Measurement: \_\_\_\_\_ +2= F: \_\_\_\_\_

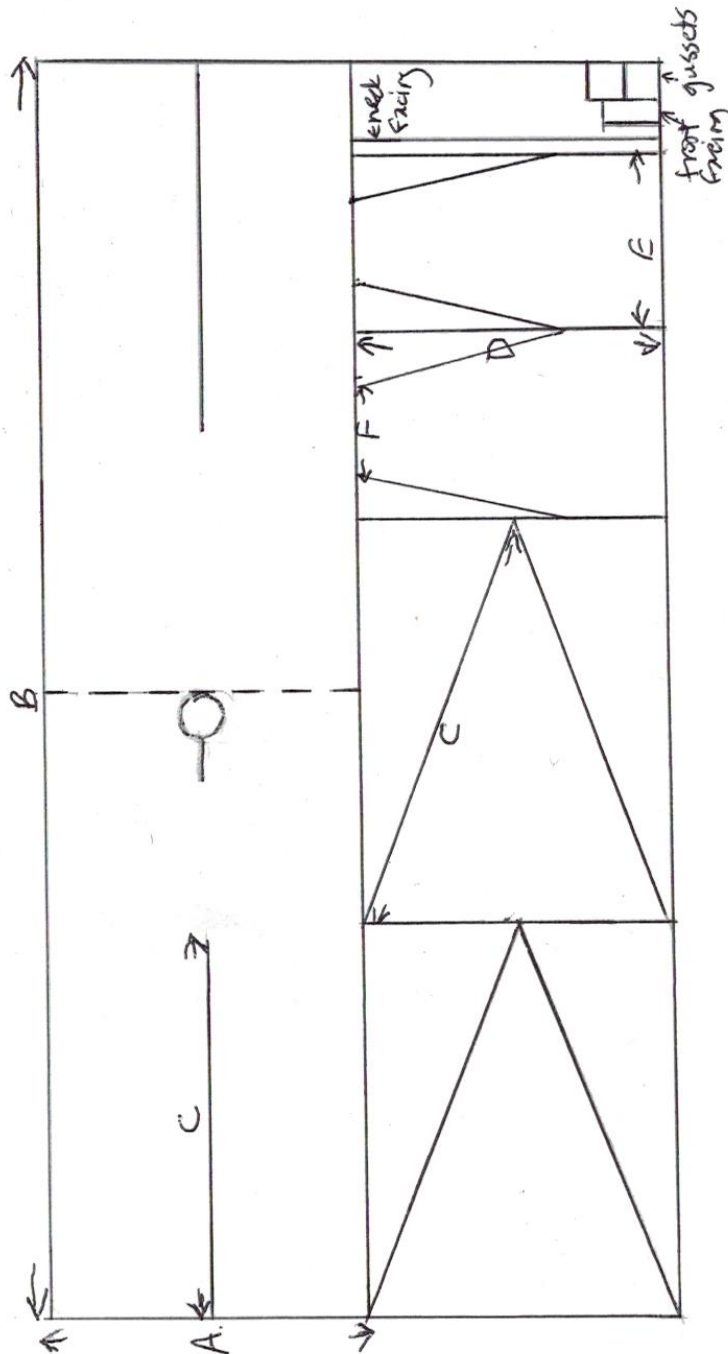

## Cutting the Fabric

1. Find Measurements A and B. Transfer them to your fabric to mark out the size of your main rectangular body piece. Cut out the main body piece and set the rest of your fabric aside for now.
2. Fold main body piece in half to find shoulder. Cut a round head hole 4-5 inches across, centred on the front with top of circle on shoulder fold. Cut a slit about 3-4 inches long straight down the front from the bottom of the circle. Try on the main body piece to make sure you can get it over your head. If you can't, make the slit a little longer. If the neck hole doesn't sit nicely on your shoulders, you can make it a little bigger. Do this in very small cuts! You can't make the hole smaller once it's cut.
3. Find your natural waist, and mark the spot with a pin. You will use that pin to find Measurement C.
4. Measure the distance from the edge of the fabric on your arm to the base of your thumb. Use that measurement to find Measurement D.
5. Measure the widest part of your biceps and the widest part of your hand, and use those to get Measurements E and F.
6. Use Measurements C, D, E and F to cut out the skirt gores and the sleeves. Also, cut two squares 4-7 inches wide (larger chested people should take a larger square), a rectangle about two inches wide and two inches longer than the neck slit in the main body piece, plus a long strip an inch wide and several inches longer than what's needed to go around the neck circle.

### Cutting Variations:

The cutting diagram shows a keyhole neckline, with a rectangular facing for the front slit, and a  $\frac{3}{4}$  inch strip to finish the neckhole edge. You could choose to have a V-neck or a square neckhole, which could be finished with a strip or by turning back and hemming.

The cutting diagram shows long tapered sleeves, but you could choose a wider sleeve either full length or elbow length. The shorter wider sleeve would usually be worn over a long tapered sleeve on the undertunic.

## Sewing Instructions

All seam allowances are  $\frac{1}{2}$  inch, except  $\frac{1}{4}$  inch for the neckline, and where the seam allowance of the body piece tapers to nothing at the top of the centre gore. Be sure to reverse stitch at the end of each seam, to secure the stitches and give strength where seams meet.

Order of construction:

- 1) Finish the neckline, according to your neckline variation.
- 2) Set in front and back gores, with the top of the gore sitting  $\frac{1}{2}$  inch past the top of the slit. Sew one side at a time, with the seam allowance of the main body tapering to nothing at the top. Turn the gore to the inside, start where you ended, and do the other side, tapering the seam allowance of the main body from nothing to  $\frac{1}{2}$  inch at the top.
- 3) Add side gores front and back, leaving  $\frac{1}{2}$  inch unsewn on top.
- 4) Add sleeves, centred on shoulder fold.
- 5) Add armpit gussets into the right angle formed where the sleeve meets the front body. Use two seams, with the stitching butting together in the corner.
- 6) Sew up the sides, in order: Main sleeve, first edge of armpit gusset to sleeve, second edge of armpit gusset to main body, main body sides, side gores. Stitch exactly to the next construction line where the seams meet, and then start stitching again at each seam.
- 7) Hem sleeves and bottom edge with a narrow double fold.

When adding side gores, sleeves, and gussets, and stitching up the sides, stop stitching  $\frac{1}{2}$  inch from the tops of the gores and the sides of the sleeves and gussets. That  $\frac{1}{2}$  inch will be needed for the seam allowances in the other direction, wherever two seams come together.

Press seams open as you go. Where several lines of stitches come together, press each seam open, folding the others away as you press. They won't all lie perfectly flat, but as long as each one is pressed open at some point, it will look fine.

All seam allowances and tops of the gores need to be finished after being sewn (straight sides can be zigzagged in advance, but not the bias edges). The easiest way to do that is to zigzag the raw edges. If it suits you better, you can flat fell the seams, or turn under and sew.